

PRESS RELEASE

Düsseldorf, November 21, 2019

New AOD converter torque retainer from SMS group

Successful commissioning and quick acceptance at NAS

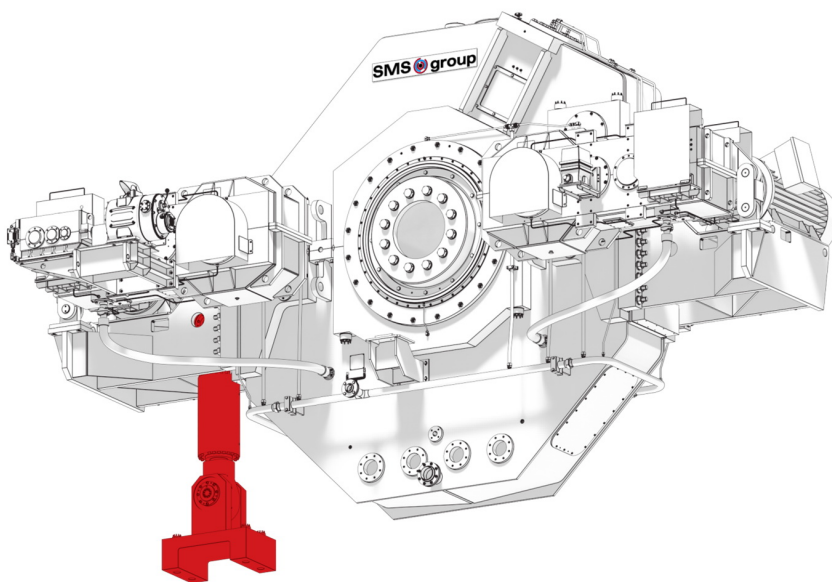

Gear unit of an AOD converter with vertical torque retainer from SMS group.

For North American Stainless (NAS) in Ghent, Kentucky, SMS group has successfully commissioned a torque retainer for the 160-ton AOD converter no. 1. The customer issued the final acceptance certificate

shortly thereafter.

The aim of the revamp – which was to reduce the torque that had previously been causing uncontrolled vibrations and damage to the bull gear, bearings, and foundations of the converter drive during AOD converter operation – was fully achieved in every respect. As a result, the uncontrolled vibrations in the gear unit and converter vessel were substantially reduced. The target values were achieved under production conditions shortly after commissioning.

SMS group supplied the torque retainer as a compact electrohydraulic unit. The scope of supply also included the engineering, supervision of the erection and installation work, and technical assistance during commissioning. Both the cold and hot commissioning were completed jointly with the customer, and the latter was performed while production was going on.

This is where NAS put SMS group's proven installation concept into action. Thanks to effective joint planning, it was possible to bring forward the plant shutdown date.

NAS is very satisfied with the results. The availability and operational reliability of the AOD converter have been significantly improved. Gear unit maintenance will also be drastically reduced. This revamp means NAS is able to utilize larger tuyeres and thus increase the blowing rate.

Duncan Bassett, Head of Mechanical Maintenance at NAS: "What impresses us is just how quiet the AOD converter and its entire surroundings are. The integration of the torque retainer in the existing converter went without a hitch, and the electrical and automation systems were adapted especially for us. From a technical and economic perspective, this torque retainer from SMS group is just the right solution."

The torque retainer from SMS group has already been successfully installed in Acerinox's plants in Columbus Stainless, Middelburg, South Africa (two AOD converters), and at Acerinox Europe S.A.U., Los

Barrios (Cádiz), Spain.

SMS group is a group of companies internationally active in plant construction and mechanical engineering for the steel and nonferrous metals industry. It has some 14,000 employees who generate worldwide sales of more than EUR 2.8 billion. The sole owner of the holding company SMS GmbH is the Familie Weiss Foundation.